

Project Name:	Notes:	Date:	Type:
---------------	--------	-------	-------

**DESCRIPTION**

Built to meet standards needed for gas station use, the CAG is available in 100W and 150W, providing efficient and dynamic lighting source.

Ideal use for lighting gas stations, carports, parking garages, underpasses or other lighting locations.



**CONSTRUCTION**

Professional optical technology to obtain 122 lm/W, and delivers light downward in a wide projection. Larger size, aluminum heat sink is designed for better cooling to ensure long life performance.

**ELECTRICAL**

Luminaire is built with the highest quality 100-277VAC drivers.

**ENERGY SAVINGS**

50% more energy savings compared to halogen lamps.

**CERTIFICATION**

UL Listed, FCC, RoHS, CE, IP65 Rated

**TECHNICAL SPECIFICATION**

WATTAGE	100W
LUMENS	12,600 lumens
EFFICACY	130 lm/W
VOLTAGE	AC100-277V
POWER FREQUENCY	50/60 Hz
CCT	5000K (other CCT custom order)
CRI	Ra>80
LIGHTING ANGLE	110°
WORKING TEMP.	-40°F - +104°F
STORAGE TEMP.	-40°F - +158°F
IP RATING	IP65 Wet Location
DIMMABLE	Non-dimmable
POWER FACTOR	>0.9
THD	≤10%
WARRANTY	5 year limited
PORTOR CAT#	PT-CAG-100W-5K



**MODEL NUMBER(S)**

MODEL#	WATTS	LUMENS	LM/WATT	CCT	CRI	VOLTAGE
<b>TS-INC10-100W</b>	100W	12,600	130	5000K	>80	AC 100/277V
<b>TS-INC15-150W</b>	150W	18,000	122	5000K	>80	AC 100/277V

Project Name:	Notes:	Date:	Type:
---------------	--------	-------	-------

**DIMENSION**

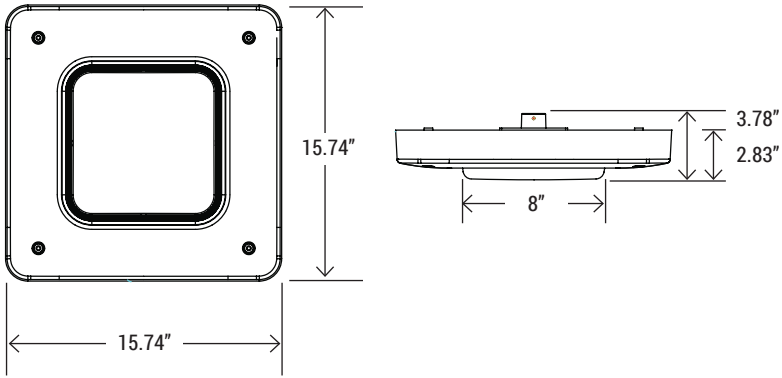

**PHOTOMETRY**

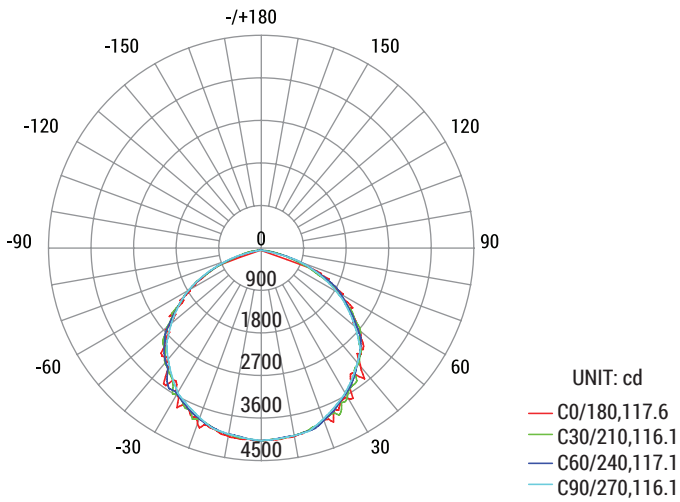

Average Beam Angle (50%) : 116.7 degree