

Project Name:	Notes:	Date:	Type:
---------------	--------	-------	-------

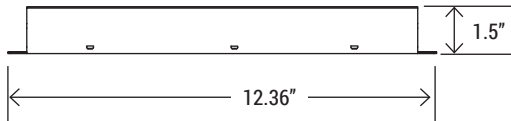
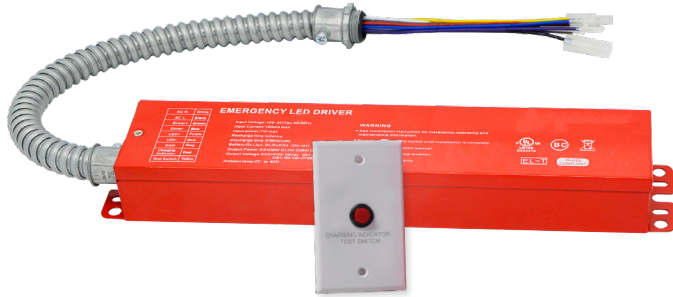

### FEATURES

- Emergency battery for use with external drives
- Low energy consumption CEC compliance
- Constant output power
- Self-testing
- High temperature protection
- Surge protection: Line-Neutral 3KV

### LISTING

- Listed to UL924 and tested to CSA C22.2 No. 141 field or factory installation
- UL Listed for US and Canada

### TECHNICAL SPECIFICATION

EMERGENCY POWER	15W / 30W
INPUT VOLTAGE	100-277 VAC
POWER FREQUENCY	50/60 Hz
INPUT CURRENT	100mA max
INPUT POWER RATING	7W
RECHARGE TIME	24 hrs
OUTPUT VOLTAGE	25-50 VDC
EMERGENCY OPERATION	90 mins
BATTERY TYPE	Li-ion
AMBIENT TEMP.	32°F - 122°F
WARRANTY	5 year limited
WEIGHT	2.66 lbs (1.207 kg)



### CAUTION:

- In order to avoid electric shock, during AC operation, do not touch or remove any wires.
- During emergency operation, before touching or disconnecting the wires, press the test button to turn the LED lamp and indicator light off to avoid electric shock .

Project Name:	Notes:	Date:	Type:
---------------	--------	-------	-------

**WIRING DIAGRAM**

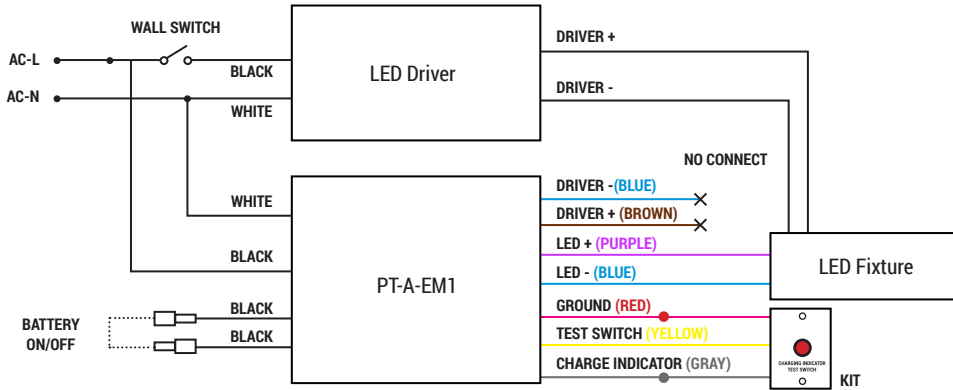

**(WHEN DRIVER POWER IS MORE THAN 100W)**

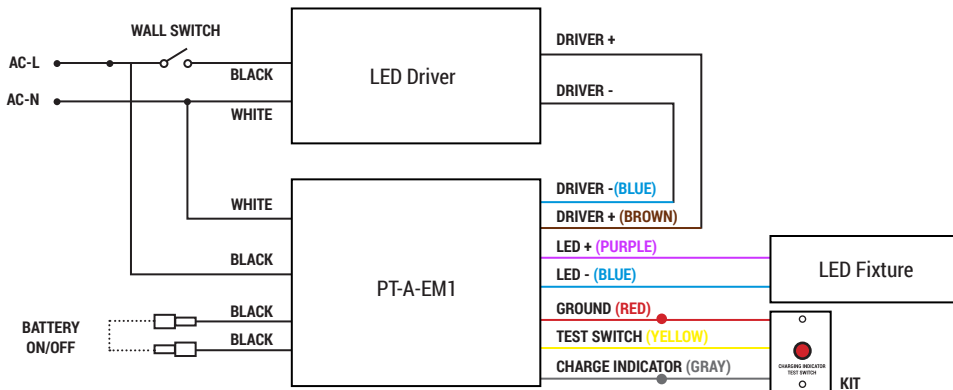

**(WHEN DRIVER POWER IS LESS THAN 100W)**

**OPERATION:**

WHEN AC POWER FAILS, EMERGENCY LED DRIVER IMMEDIATELY SWITCHES TO THE EMERGENCY MODE, OPERATING THE LEDS AT A REDUCED LUMEN OUTPUT FOR A MINIMUM OF 90 MINUTES. WHEN AC POWER IS RESTORED, THE EMERGENCY DRIVER AUTOMATICALLY RETURNS TO THE CHARGING MODE.