

Catalog Number:	Project Name:	Note:	Date:	Type:
-----------------	---------------	-------	-------	-------

DESCRIPTION

Portor's second generation commercial grade recessed downlight is wattage and color tunable, which can be programmed with a CCT of 2700K, 3000K, 3500K, 4000K, or 5000K, eliminating the need to stock multiple color temperatures.

Ideal use for commercial complexes, hospitality, healthcare industry, schools, shopping centers, industrial areas and hotels.



LED RETROFIT
COMMERCIAL
GRADE DOWNLIGHT

← TUNABLE →
5 CCT
SELECTABLE

WATTAGE
3W
SELECTOR

Baffle Finish

Direct Mounting

NO RECESSED HOUSING NEEDED

FOR RETROFIT OR NEW CONSTRUCTION INSTALLATION



CONSTRUCTION

PC driver housing and aluminum baffle with architectural white finish. Standard gasket included to ensure proper seal.

ELECTRICAL

Luminaire is built with the highest quality LED drivers, ensuring energy efficiency. Optional emergency battery pack.

ENERGY SAVINGS

80% more energy savings than traditional lamps. Low heat production requires less air-conditioning requirements, further increasing energy cost savings.

INSTALLATION

The adjustable housing clips allow for installation in a large range of commercial and architectural housings ranging from 6.0"-7.4" (153-190mm). These spring-action clips push up easily and fit securely for both retrofit and new construction installations.

LISTING

ETL Listed, FCC, RoHS, CE & Energy Star Listed

NOMINAL WATTAGE	DELIVERED LUMENS	EFFICACY
12W	1200 LM	up to 100 lm/W
17W	1700 LM	
22W	2200 LM	

Based on 4000K setting. Actual lumens may vary.

TECHNICAL SPECIFICATION

WATTAGE	12W/17W/22W
CCT	2700K 3000K 3500K 4000K 5000K
CRI	96
DIMMABLE	*0-10V, 5-100% smooth dimming
BEAM ANGLE	100°
VOLTAGE	120V-277V
POWER FREQUENCY	50/60 Hz
POWER FACTOR	>0.9
LIFESPAN	50,000 hrs @ L70 lifetime
RATING	Suitable for wet locations
WARRANTY	5 year limited

**Must use 0-10v dimming wire. Not compatible for line voltage dimming.*



ORDERING SAMPLE: PT-CDL2-6I-5C3P

Series	Aperture	CCT (Selectable)	Wattage (Selectable)	Finished	*Accessories/Options	
PT-CDL2 Commercial Grade Downlight	6I (6")	5C (2700K / 3000K / 3500K / 4000K / 5000K)	3P (12W / 17W / 22W)	White (Standard)	EM Battery	TRIM RING
					Blank (no option) PT-EMG-8W PT-EMG-15W	TRR-CDL-6I-BK TRR-CDL-6I-BN TRR-CDL-6I-BZ

Catalog Number:	Project Name:	Note:	Date:	Type:
-----------------	---------------	-------	-------	-------

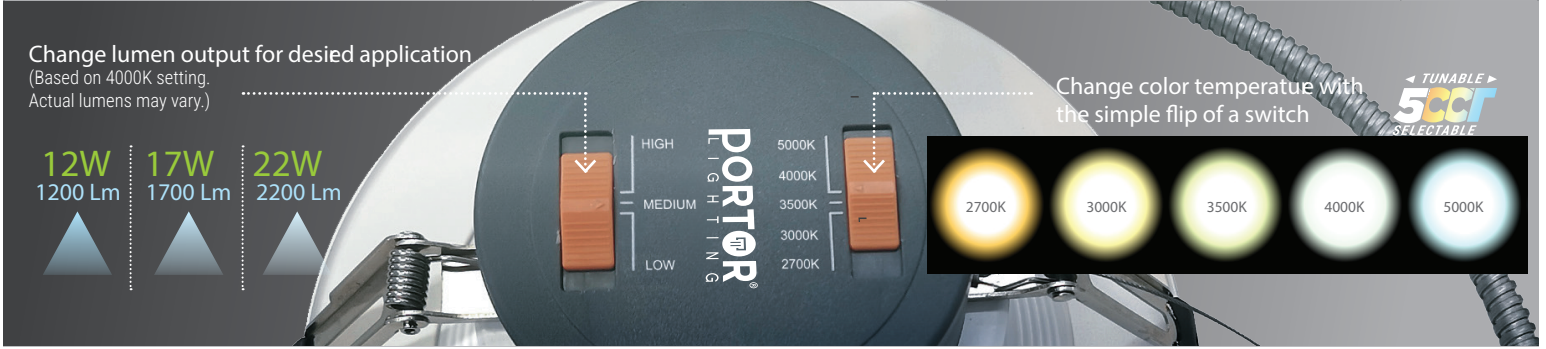

DIMENSION

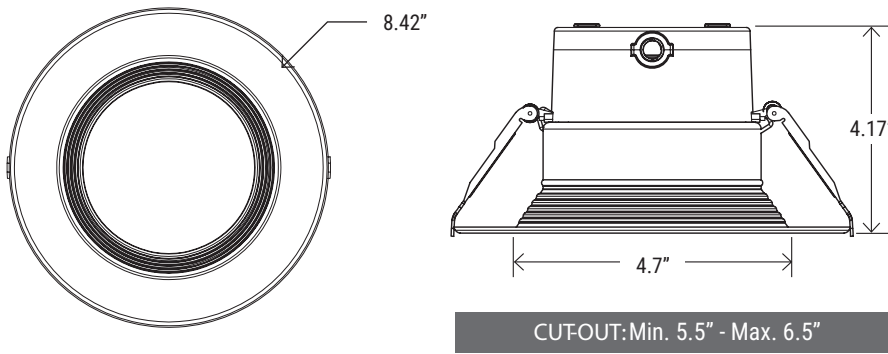

*EM BATTERY OPTION (SOLD SEPARATE)

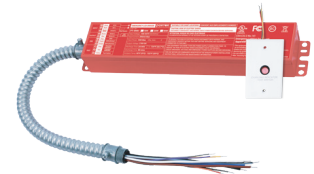

PT-EMG-8W
PT-EMG-15W
LED Emergency Driver

SMOOTH TRIM RING REPLACEMENT (SOLD SEPARATELY)



MOUNTING OPTIONS



QTY/CARTON

4
PIECES

PHOTOMETRY (Luminous Intensity Distribution Diagram)

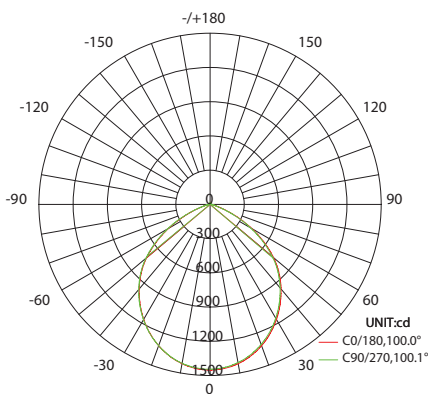

AVERAGE BEAM ANGLE(50%):100.0 DEG

12W @ 4000K

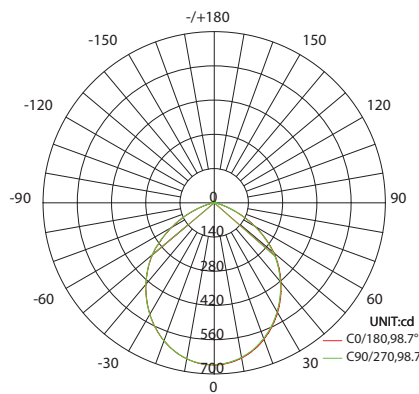

AVERAGE BEAM ANGLE(50%):98.7 DEG

17W @ 4000K

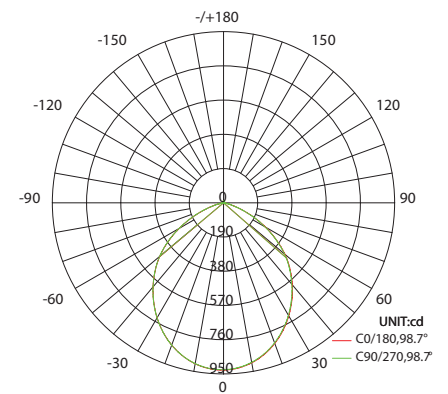

AVERAGE BEAM ANGLE(50%):98.7 DEG

22W @ 4000K