

Catalog Number:	Project Name:	Note:	Date:	Type:
-----------------	---------------	-------	-------	-------

Portor's second generation AL2N Area Light White Series is highly energy efficient and provides advanced optical control. The ultra slim profile delivers enhanced performance for general area lighting applications. The robust die-cast housing provides excellent thermal management for longer life and can withstand everyday harsh outdoor environments.

Ideal use for parking lots, car dealerships, roadways, walkways, school campuses, shopping centers and industrial areas



NOT FOR USE AS AN UP LIGHT

CONSTRUCTION

Die-cast aluminum body combined with state of the art heat dissipation. Waterproof, built rugged for outdoor harsh conditions.

ELECTRICAL

Built with the highest quality, long lasting Universal Voltage driver 100V-27V (347V-480V optional), and water resistant LED chips.

OPTICAL SYSTEM

Comes standard with Type III optics designed to reduce glare and improve light distribution through precision formed lens optics. Type V is available.

MOUNTING

Multiple mounting options available: Slipfitter, square-pole mount, round-pole mount, u-bracket and trunnion mount.

SENSOR READY

Photocell and motion sensor available.

DIMMING

1-10V dimmable

ENERGY SAVINGS

Over 70% energy savings than traditional fixtures, low heat productions requires less maintenance and operation cost.

LISTING

UL Listed, RoHS, IP65 rated

WARRANTY

5 year Limited Warranty, Rated for 50,000 hours.

WATTAGE	DELIVERED LUMENS	EFFICACY
200W	29,757	148 lm/W
240W	35,511	147 lm/W
300W	45,353	148 lm/W

Based on 5000K, 70 CRI. Actual lumens may vary.

TECHNICAL SPECIFICATION

CCT	3000K/4000K/5000K
CRI	70+
DIMMABLE	1-10V dimming
DISTRIBUTION	Type III (Standard), Type IV & V (Optional)
VOLTAGE	100V-277V (347V-480V optional)
SENSOR	Photocell and motion sensor capable
POWER FREQUENCY	50/60 Hz
POWER FACTOR	>0.9
THD	≤15%
WORKING TEMPERATURE	-40°F ~ 122°F
IP RATING	IP65 Wet Location
WARRANTY	5 year limited



ORDERING SAMPLE: PT-AL2N-300-3CP

Series	CCT/Wattage	Finish	Distribution	**Mounting (Not included)		**Accessories/Options		
				Bronze	White	Photocell	Sensor	Shield
PT-AL2N-300-3CP Second Generation Area Light Series	(30K/40K/50K) (200W/240W/300W) Selector	Blank (Bronze) W (White)	Blank (Type III) *T4 (Type IV) *T5 (Type V)	SF-AL2 SPM-AL2 SAM-AL2 TM-AL2 UB-AL2-2037	SF-AL2-W SPM-AL2-W SAM-AL2-W TM-AL2-W UB-AL2-2037-W	PC PC-HV	MS-UNI-MW2 MSH-RC2 (Required)	SHD-AL2-2037 SHD-AL2-2037-W

*Special order required

**Sold separate

Catalog Number:	Project Name:	Note:	Date:	Type:
-----------------	---------------	-------	-------	-------

DIMENSION

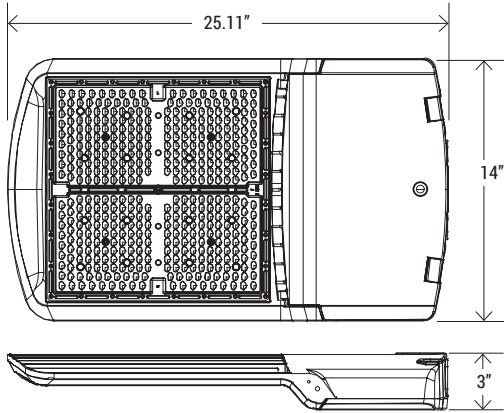

PHOTOCELL OPTION



PC
Photocell
(120V-277V)



PC-HV
Photocell (480V)

SENSOR OPTION



MS-UNI-MW2
Universal Microwave Motion Sensor



MSH-RC2
Remote Control (Required)

SHIELD OPTION



SHD-AL2-2037
SHD-AL2-2037-W
(200W/240W/300W)

Shield for AL Series

***MOUNTING OPTION (SOLD SEPARATELY)**



SF-AL2 (-W)
Slipfitter



SPM-AL2 (-W)
Adjustable Mount For
Square/Round Pole



SAM-AL2 (-W)
Straight Arm Mount for
Square Pole



TM-AL2 (-W)
Trunnion Mount

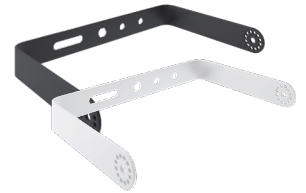

UB-AL2-2037 (-W)
U-Bracket Mount

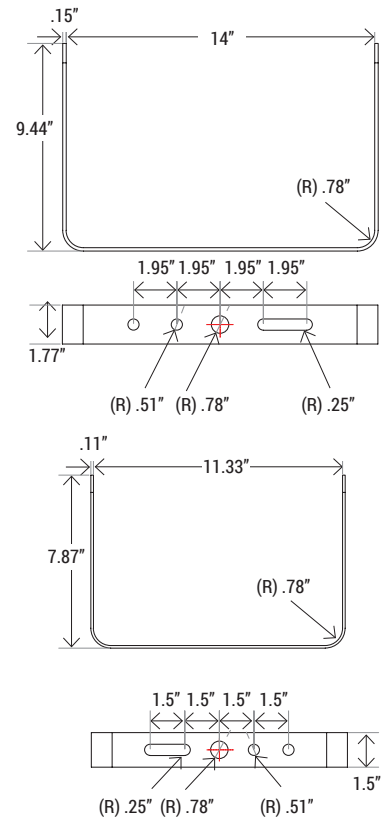
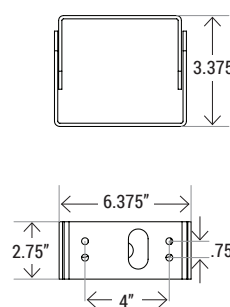
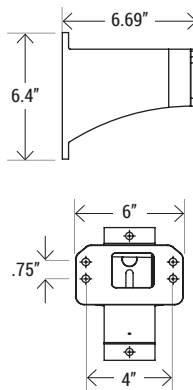
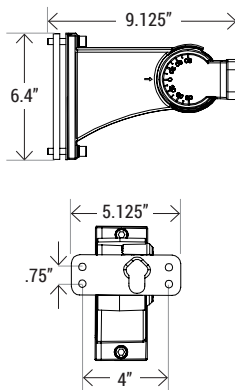
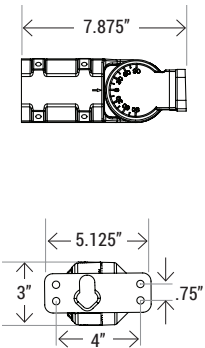

Catalog Number:	Project Name:	Note:	Date:	Type:
-----------------	---------------	-------	-------	-------

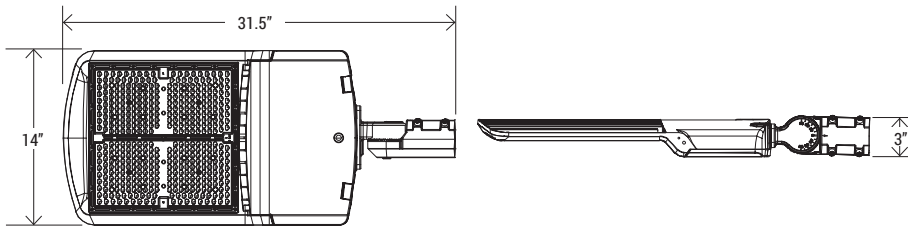

EPA	0.8 ft²
Net Weight	17.42 lbs
Gross Weight	20.72 lbs
Dimension	14" x 31.5" x 3"

B	U	G
4	0	4

*WITH SLIPFITTER MOUNTING

CONFIGURATION	1	2 @ 180°	2 @ 90°	3 @ 90°	3 @ 120°	4 @ 90°
EPA	0.8 ft²	1.6 ft²	1.2 ft²	2.0 ft²	1.7 ft²	2.3 ft²
Net Weight	17.42 lbs	34.84 lbs	34.84 lbs	52.26 lbs	52.26 lbs	69.68 lbs

ELECTRICAL LOAD

WATTAGE	120V	208V	240V	277V	347V	480V
200W	1.68 Amp	0.96 Amp	0.83 Amp	0.72 Amp	0.57 Amp	0.42 Amp
240W	2.0 Amp	1.15 Amp	1.00 Amp	0.87 Amp	0.69 Amp	0.50 Amp
300W	2.5 Amp	1.44 Amp	1.25 Amp	1.08 Amp	0.86 Amp	0.62 Amp

DISTRIBUTION

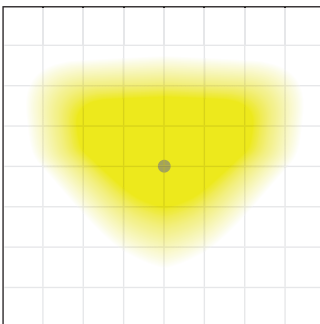

TYPE III
Type III distribution provides a wide, round pattern and yields an even light disbursement since the light projects outwards.

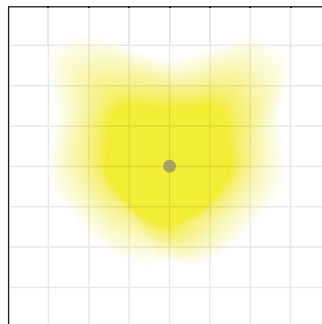

TYPE IV
Type IV has a preferred lateral width of 60° make it ideal for parking area and courtyard.

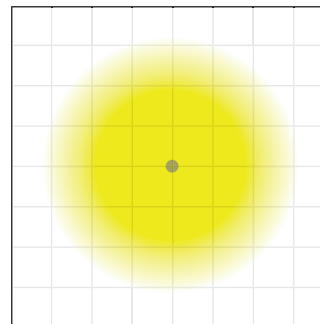

TYPE V
Type V provides central circular or square design pattern, equally across all angles from a central point.

QTY/CARTON

1
PIECE