

Catalog Number:	Project Name:	Note:	Date:	Type:
-----------------	---------------	-------	-------	-------

8th Generation Flat Panel

Portor's 8th Generation BLP series produce industry-leading performance with deep energy savings and continuous dimming. The compact, slick profile produces uniform and glare free lumen output.

Perfect application for retail stores, schools, offices, markets and restaurant.



CONSTRUCTION

Cold-rolled steel and extruded aluminum frame, prefabricated paint with matte white finished. Slim profile design. Integrated T-Bar mounting clips built in onto the fixture. Easy installation

ELECTRICAL

Luminaire is built with the highest quality driver that is Universal Voltage (120V-27V), uses long lasting, highly-efficient LED packages.

DRIVER

Driver is fixed on the back of the panel or side to prevent mis-handling during shipment.

OPTICAL SYSTEM

Back-lit optics produces uniform light output, diffuser lens reduces glare and improve overall energy efficiency.

DIMMING

Continuous dimming (0-10V) comes standard.

ENERGY SAVINGS

Over 50% energy savings than traditionally fluorescent fixtures, low heat productions requires less maintenance and operation cost.

LISTING

UL Listed, DLC Listed

WARRANTY

5 Years Limited Warranty, Rated for 50,000 hours

WATTAGE	DELIVERED LUMENS	EFFICACY
25W	2,750	110 lm/W
30W	3,300	
40W	4,400	

Based on 3500K, 80 CRI. Actual lumens may vary.

TECHNICAL SPECIFICATION

CCT	3500K/4000K/5000K
CRI	80+
DIMMABLE	0-10V dimmable
VOLTAGE	120V-277V
POWER FREQUENCY	50/60 Hz
POWER FACTOR	>0.9
THD	≤20%
DRIVER EFFICIENCY	>85%
RATING	IP40, Suitable for damp locations
WARRANTY	5 year limited



ORDERING SAMPLE: - - - -

Series - Size - CCT/Wattage	Accessories/Options (Sold separately)				
PT-BLP8-22-3CP (CCT: 3500K/4000K/5000K) (Wattage: 25W/30W/40W)	EM Battery	Surface/Flange Kit	Pendant Cable	Other	Control Lutron AWN
	___ Blank PT-EMG-8W PT-EMG-15W	___ Blank SMK-BLP-22 FK-22	___ Blank A-CBL-BLP-224	___ Blank JP-BPL MC-5W-SC-6F MC-6W-SC-6F MC-5W-SN-HD3-6F MC-6W-SN-HD3-6F	

Catalog Number:	Project Name:	Note:	Date:	Type:
-----------------	---------------	-------	-------	-------



Front



Back

DIMENSION

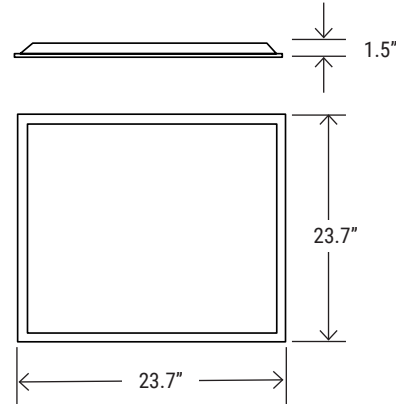

QTY/CARTON

2

PIECES

Maintenance-free optical module sealed for life; no internal cleaning required.

SURFACE MOUNT/FLANGE KIT



SMK-BLP-22
Surface mount kit for the 2x2 panel

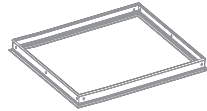

FK-22
Flange kit for the 2x2 panel



AWN
Athena Wireless Node



EM BATTERY OPTION



PT-EMG-8W / PT-EMG-15W
Low Voltage EM Battery

PENDANT CABLE



A-CB-BLP-224
5' Aircraft Cable

JUNCTION BOX



JB-BPL
Junction box
(Field installation)

OTHER



MC-5W-SC-6F / MC-6W-SC-6F (Screw-in)
MC-5W-SN-6HD3F / MC-6W-SN-6HD3F (Snap-in)
MC series metal flex whip

CATALOG NUMBER	WATTAGE	DELIVERED LUMENS	EFFICACY	DLC PRODUCT ID	CLASSIFICATION
PT-BPL8-22-3CP	25W	27580	110 lm/W	S-6JAU2P	 REGULAR
	30W	3300			
	40W	4400			

Based on 3500K, 80 CRI. Actual lumens may vary.

Catalog Number:	Project Name:	Note:	Date:	Type:
-----------------	---------------	-------	-------	-------

MOTION SENSORS



PT-BTN
Bluetooth Node



PT-MS-21-BT-JB
Bluetooth Dual Tech
Ceiling Sensor

CONTROLLERS



PT-BT-6
Bluetooth Fixture Sensor



PT-BTC-EM
Bluetooth EM Controller

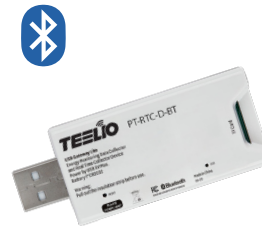

PT-RTC-D-BT
Bluetooth Real Time Clock/
Energy Monitoring USB-A
Dongle



PT-GTB-D-BT
Bluetooth Gateway Bridge
USB-A Dongle



WALL SWITCHES



PT-5WS-BT-B
Battery 5 Button Wall Switch



PT-3WS-BT-B
Battery 3 Button Wall Switch



PT-3WS-BT-A
AC 3 Button Wall Switch



PT-1WS-MS-BT-A
PIR Sensor Wall Switch