

Catalog Number:	Project Name:	Note:	Date:	Type:
-----------------	---------------	-------	-------	-------

**8th Generation Flat Panel**

Portor's 8th Generation BLP series produce industry-leading performance with deep energy savings and continuous dimming. The compact, slick profile produces uniform and glare free lumen output.

Perfect application for retail stores, schools, offices, markets and restaurant.



**CONSTRUCTION**

Cold-rolled steel and extruded aluminum frame, prefabricated paint with matte white finished. Slim profile design. Integrated T-Bar mounting clips built in onto the fixture. Easy installation

**ELECTRICAL**

Luminaire is built with the highest quality driver that is Universal Voltage (120V-27V), uses long lasting, highly-efficient LED packages.

**DRIVER**

Driver is fixed on the back of the panel or side to prevent mis-handling during shipment.

**OPTICAL SYSTEM**

Back-lit optics produces uniform light output, diffuser lens reduces glare and improve overall energy efficiency.

**DIMMING**

Continuous dimming (0-10V) comes standard.

**ENERGY SAVINGS**

Over 50% energy savings than traditionally fluorescent fixtures, low heat productions requires less maintenance and operation cost.

**LISTING**

UL Listed, DLC Listed

**WARRANTY**

5 Years Limited Warranty, Rated for 50,000 hours (See Warranty documentation for details).

WATTAGE	DELIVERED LUMENS	EFFICACY
25W	2975	119 lm/W
30W	3480	116 lm/W
40W	4400	110 lm/W

*Based on 3500K, 80 CRI. Actual lumens may vary.*

**TECHNICAL SPECIFICATION**

CCT	3500K/4000K/5000K
CRI	80+
DIMMABLE	0-10V dimmable
VOLTAGE	120V-277V
POWER FREQUENCY	50/60 Hz
POWER FACTOR	>0.9
THD	≤20%
DRIVER EFFICIENCY	>85%
RATING	IP40, Suitable for damp locations
WARRANTY	5 year limited



ORDERING SAMPLE:  -  -  -  -

Series - Size - CCT/Wattage
<b>PT-BLP8-14-3CP</b> (CCT: 3500K/4000K/5000K) (Wattage: 25W/30W/40W)

Accessories/Options (Sold separately)			
EM Battery	Surface/Flange Kit	Pendant Cable	Other
___ Blank PT-EMG-8W PT-EMG-15W	___ Blank SMK-BLP-14 FK-14	___ Blank A-CBL-BLP-224	___ Blank JP-BPL MC-5W-SC-6F MC-6W-SC-6F MC-5W-SN-HD3-6F MC-6W-SN-HD3-6F

Catalog Number:	Project Name:	Note:	Date:	Type:
-----------------	---------------	-------	-------	-------



Front



Back

**DIMENSION**

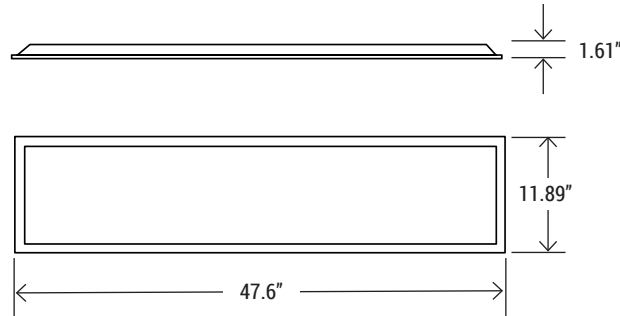

QTY/CARTON

**2**

PIECES

Maintenance-free optical module sealed for life; no internal cleaning required.

**EM BATTERY OPTION**



PT-EMG-8W / PT-EMG-15W  
Low Voltage EM Battery

**SURFACE MOUNT/FLANGE KIT**



SMK-BLP-14  
Surface mount kit for the 1x4 panel



FK-14  
Flange kit for the 1x4 panel

**PENDANT CABLE**



A-CB-BLP-224  
5' Aircraft Cable

**JUNCTION BOX**



JB-BPL  
Junction box  
(Field installation)

**OTHER**



MC-5W-SC-6F / MC-6W-SC-6F (Screw-in)  
MC-5W-SN-6HD3F / MC-6W-SN-6HD3F (Snap-in)  
MC series metal flex whip

CATALOG NUMBER	WATTAGE	DELIVERED LUMENS	EFFICACY	DLC PRODUCT ID	CLASSIFICATION
PT-BLP8-14-3CP	25W	27580	110 lm/W	S-GWSTA2	 REGULAR
	30W	3300			
	40W	4400			

Based on 3500K, 80 CRI. Actual lumens may vary.

Catalog Number:	Project Name:	Note:	Date:	Type:
-----------------	---------------	-------	-------	-------

**8th Generation Flat Panel**

Portor's 8th Generation BLP series produce industry-leading performance with deep energy savings and continuous dimming. The compact, slick profile produces uniform and glare free lumen output.

Perfect application for retail stores, schools, offices, markets and restaurant.



**CONSTRUCTION**

Cold-rolled steel and extruded aluminum frame, prefabricated paint with matte white finished. Slim profile design. Integrated T-Bar mounting clips built in onto the fixture. Easy installation

**ELECTRICAL**

Luminaire is built with the highest quality driver that is Universal Voltage (120V-27V), uses long lasting, highly-efficient LED packages.

**DRIVER**

Driver is fixed on the back of the panel or side to prevent mis-handling during shipment.

**OPTICAL SYSTEM**

Back-lit optics produces uniform light output, diffuser lens reduces glare and improve overall energy efficiency.

**DIMMING**

Continuous dimming (0-10V) comes standard.

**ENERGY SAVINGS**

Over 50% energy savings than traditionally fluorescent fixtures, low heat productions requires less maintenance and operation cost.

**LISTING**

UL Listed, DLC Listed

**WARRANTY**

5 Years Limited Warranty, Rated for 50,000 hours

WATTAGE	DELIVERED LUMENS	EFFICACY
25W	2,750	110 lm/W
30W	3,300	
40W	4,400	

*Based on 3500K, 80 CRI. Actual lumens may vary.*

**TECHNICAL SPECIFICATION**

CCT	3500K/4000K/5000K
CRI	80+
DIMMABLE	0-10V dimmable
VOLTAGE	120V-277V
POWER FREQUENCY	50/60 Hz
POWER FACTOR	>0.9
THD	≤20%
DRIVER EFFICIENCY	>85%
RATING	IP40, Suitable for damp locations
WARRANTY	5 year limited



ORDERING SAMPLE:  -  -  -  -

Series - Size - CCT/Wattage	Accessories/Options (Sold separately)				
	EM Battery	Surface/Flange Kit	Pendant Cable	Other	Control
<b>PT-BLP8-22-3CP</b> (CCT: 3500K/4000K/5000K) (Wattage: 25W/30W/40W)	___ Blank PT-EMG-8W PT-EMG-15W	___ Blank SMK-BLP-22 FK-22	___ Blank A-CBL-BLP-224	___ Blank JP-BPL MC-5W-SC-6F MC-6W-SC-6F MC-5W-SN-HD3-6F MC-6W-SN-HD3-6F	<b>Lutron AWN</b>

Catalog Number:	Project Name:	Note:	Date:	Type:
-----------------	---------------	-------	-------	-------



Front



Back

**DIMENSION**

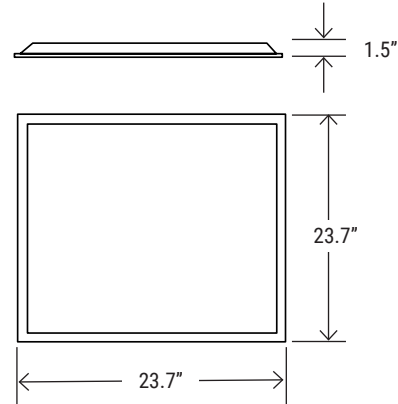

QTY/CARTON

**2**

PIECES

Maintenance-free optical module sealed for life; no internal cleaning required.

**SURFACE MOUNT/FLANGE KIT**



SMK-BLP-22  
Surface mount kit for the 2x2 panel

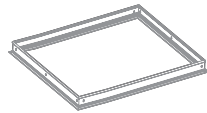

FK-22  
Flange kit for the 2x2 panel

**LUTRON**  
COMPATIBLE CONTROL



AWN  
Athena Wireless Node

**vive**  
Simple, scalable, wireless  
lighting control

**EM BATTERY OPTION**



PT-EMG-8W / PT-EMG-15W  
Low Voltage EM Battery

**PENDANT CABLE**



A-CB-BLP-224  
5' Aircraft Cable

**JUNCTION BOX**

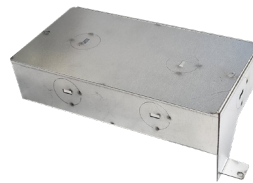

JB-BPL  
Junction box  
(Field installation)

**OTHER**



MC-5W-SC-6F / MC-6W-SC-6F (Screw-in)  
MC-5W-SN-6HD3F / MC-6W-SN-6HD3F (Snap-in)  
MC series metal flex whip

CATALOG NUMBER	WATTAGE	DELIVERED LUMENS	EFFICACY	DLC PRODUCT ID	CLASSIFICATION
PT-BPL8-22-3CP	25W	27580	110 lm/W	S-6JAU2P	 REGULAR
	30W	3300			
	40W	4400			

Based on 3500K, 80 CRI. Actual lumens may vary.

Catalog Number:	Project Name:	Note:	Date:	Type:
-----------------	---------------	-------	-------	-------

**8th Generation Flat Panel**

Portor's 8th Generation BLP series produce industry-leading performance with deep energy savings and continuous dimming. The compact, slick profile produces uniform and glare free lumen output.

Perfect application for retail stores, schools, offices, markets and restaurant.



**CONSTRUCTION**

Cold-rolled steel and extruded aluminum frame, prefabricated paint with matte white finished. Slim profile design. Integrated T-Bar mounting clips built in onto the fixture. Easy installation

**ELECTRICAL**

Luminaire is built with the highest quality driver that is Universal Voltage (120V-27V), uses long lasting, highly-efficient LED packages.

**DRIVER**

Driver is fixed on the back of the panel or side to prevent mis-handling during shipment.

**OPTICAL SYSTEM**

Back-lit optics produces uniform light output, diffuser lens reduces glare and improve overall energy efficiency.

**DIMMING**

Continuous dimming (0-10V) comes standard.

**ENERGY SAVINGS**

Over 50% energy savings than traditionally fluorescent fixtures, low heat productions requires less maintenance and operation cost.

**LISTING**

UL Listed, DLC Listed

**WARRANTY**

5 Years Limited Warranty, Rated for 50,000 hours

WATTAGE	DELIVERED LUMENS	EFFICACY
30W	3,300	110 lm/W
40W	4,400	
50W	5,500	

Based on 3500K, 80 CRI. Actual lumens may vary.

**TECHNICAL SPECIFICATION**

CCT	3500K/4000K/5000K
CRI	80+
DIMMABLE	0-10V dimmable
VOLTAGE	120V-277V
POWER FREQUENCY	50/60 Hz
POWER FACTOR	>0.9
THD	≤20%
DRIVER EFFICIENCY	>85%
RATING	IP40, Suitable for damp locations
WARRANTY	5 year limited



ORDERING SAMPLE:  -  -  -  -

Series - Size - CCT/Wattage	Accessories/Options (Sold separately)				
	EM Battery	Surface/Flange Kit	Pendant Cable	Other	Control
<b>PT-BLP8-24-3CP</b> (CCT: 3500K/4000K/5000K) (Wattage: 30W/40W/50W)	___ Blank PT-EMG-8W PT-EMG-15W	___ Blank SMK-BLP-24 FK-24	___ Blank A-CBL-BLP-224	___ Blank JP-BPL MC-5W-SC-6F MC-6W-SC-6F MC-5W-SN-HD3-6F MC-6W-SN-HD3-6F	<b>Lutron AWN</b>

Catalog Number:	Project Name:	Note:	Date:	Type:
-----------------	---------------	-------	-------	-------



Front



Back

**DIMENSION**

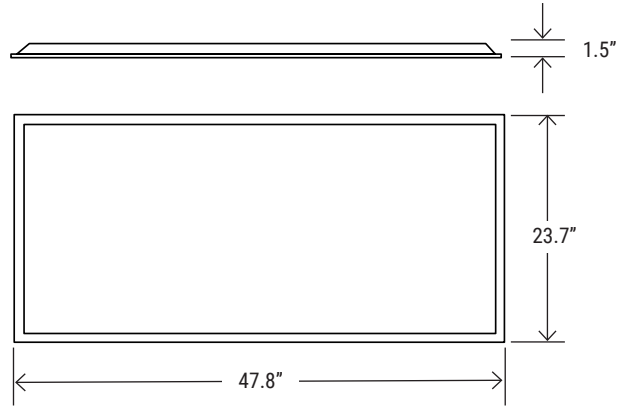

QTY/CARTON

**2**

PIECES

Maintenance-free optical module sealed for life; no internal cleaning required.

**SURFACE MOUNT/FLANGE KIT**

**LUTRON**  
COMPATIBLE CONTROL



SMK-BLP-24  
Surface mount kit for the 2x4 panel

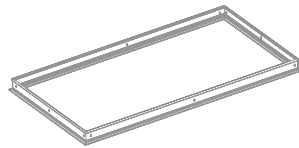

FK-24  
Flange kit for the 2x4 panel



AWN  
Athena Wireless Node



Simple, scalable, wireless  
lighting control

**EM BATTERY OPTION**

**PENDANT CABLE**

**JUNCTION BOX**

**OTHER**



PT-EMG-8W / PT-EMG-15W  
Low Voltage EM Battery



A-CB-BLP-224  
5' Aircraft Cable

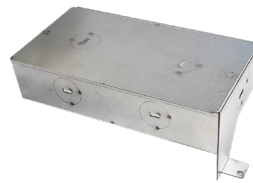

JB-BPL  
Junction box  
(Field installation)



MC-5W-SC-6F / MC-6W-SC-6F (Screw-in)  
MC-5W-SN-6HD3F / MC-6W-SN-6HD3F (Snap-in)  
MC series metal flex whip

CATALOG NUMBER	WATTAGE	DELIVERED LUMENS	EFFICACY	DLC PRODUCT ID	CLASSIFICATION
PT-BLP8-24-3CP	30W	3300	110 lm/W	S-EC7YXF	 REGULAR
	40W	4400			
	50W	5500			

Based on 3500K, 80 CRI. Actual lumens may vary.