

Project Name:	Notes:	Date:	Type:
---------------	--------	-------	-------

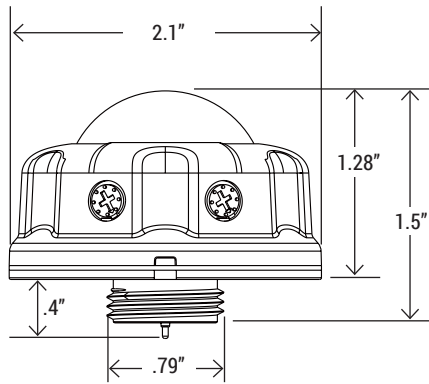

DIMENSION



**RECEPTACLE NEEDED FOR SOME PRODUCTS*
(MUST BE ORDERED SEPARATELY)**

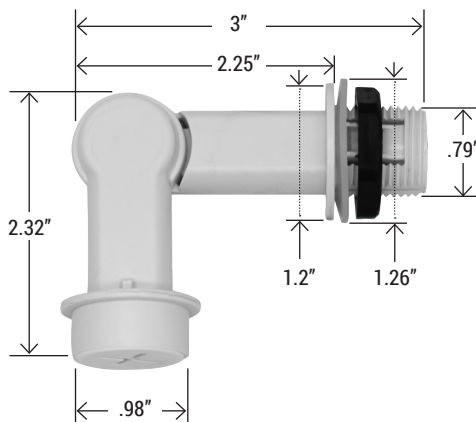

ELB-UNI

- 3 pogo-pin connection / length of the wire: 300mm
- Wire color: Black/white; Pink,Purple

* CALL FACTORY FOR DETAILS

DESCRIPTION

Portor's short pin dimmable PIR motion sensor allows a full range of control, including standby time, hold time, and daylight harvesting.

TECHNICAL SPECIFICATION

INPUT / VOLTAGE RANGE	12V DC / 10-15V DC
OPERATING CURRENT	<15mA
OUTPUT	Dim 0-10V
OPERATING TEMPERATURE	-20°C ~ 60°C
STORAGE TEMPERATURE	-40°C ~ 80°C Humidity: 85% (non-condensation)
IP RATING	IP65
WARRANTY	5-year limited

PIR INFORMATION

INFRARED WAVELENGTH	514um
OUTPUT SIGNAL PEAK	≥3500mV
PIR SENSITIVITY	3200V/M
INSTALLATION HEIGHT	12m/39ft max
DETECTION DISTANCE	≥3m/9ft
DETECTION ANGLE	≤120° Fresnel Lens

SENSOR PARAMETER

DETECTION AREA	Remote Control: 25%/50%/75%/100%
HOLD TIME	Remote Control: 5s/30s/1min/3min/5min/10min/20min/30min Rotating switch: 5s/1min/5min/10min
DAYLIGHT THRESHOLD	Remote Control: 2Lux/10Lux/30Lux/50Lux/80Lux/120Lux/200Lux/250Lux/300Lux/350Lux/400Lux/Disable
STANDBY DIMMING LEVEL	Remote Control: 10%/20%/30%/50% Rotating switch: 0%/10%/30%/50%
STANDBY PERIOD	Remote Control: 0s/10s/30s/1min/5min/10min/30min/60min/+∞
DUSK/DAWN SENSING/PHOTOCELL	<ul style="list-style-type: none"> • Daylight threshold as 30lux/50lux/80lux/120lux/200Lux/250Lux/ • 300Lux/350Lux/400Lux • Standby period as + ; • Standby dimming level as 10%/20%/30%
DAYLIGHT HARVESTING	<ol style="list-style-type: none"> 1. Adjust "daylight" value higher than 50lux 2. Preset "standby period" 0S 3. Press MW/PIR button 3 times till MW/PIR icons both blinking on LCD screen, daylight harvesting function enabled. (With BLE version, press DH button, daylight harvesting function enabled.)
OUTPUT	ON/OFF, 0-10V Dimming
WARM-UP PERIOD	45s

Project Name:	Notes:	Date:	Type:
---------------	--------	-------	-------

DETECTION COVERAGE

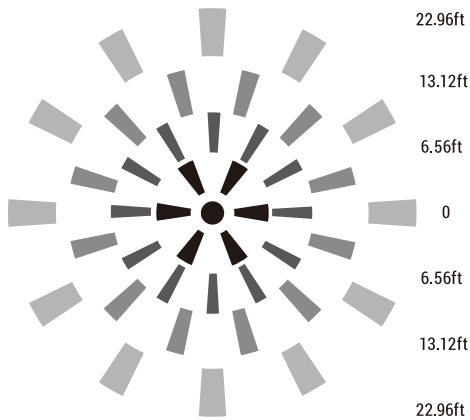

Mounting Height
<12m/39.37ft Ceiling Mounted

Detection Distance
Radius 3-7m/9.84-22.96ft

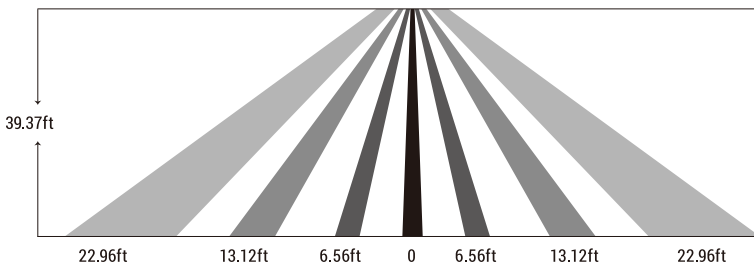

WIRING DIAGRAM

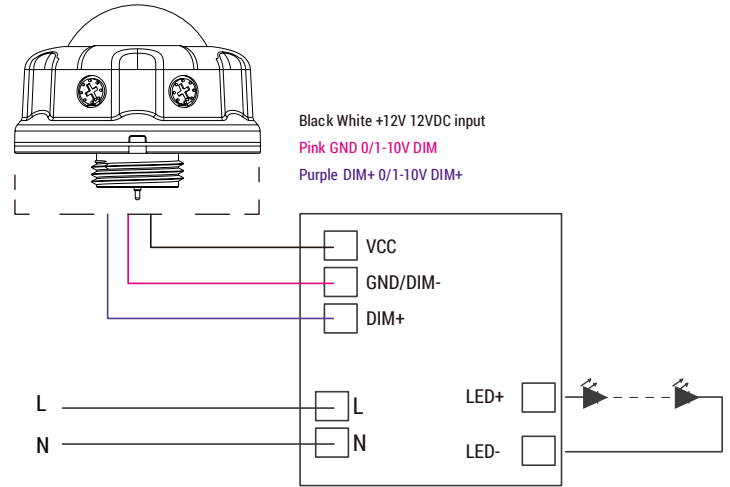

1. DAYLIGHT HARVESTING

- A. Adjust "daylight" value higher than 50lux
- B. Preset "standby period" 0S
- C. Press MW/PIR button 3 times till MW/PIR icons both blinking on LCD screen, daylight harvesting function enabled. (With BLE version, press DH button, daylight harvesting function enabled.)

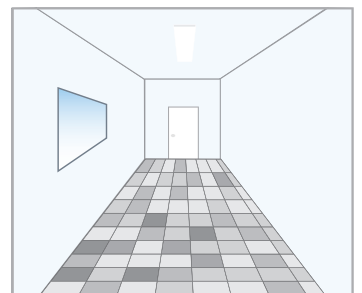
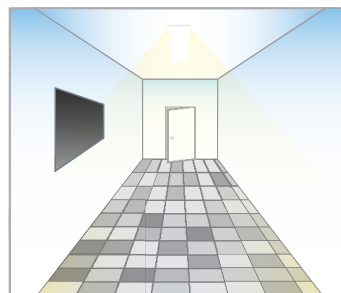
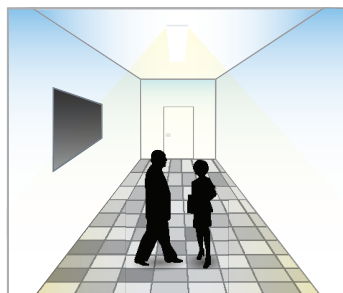
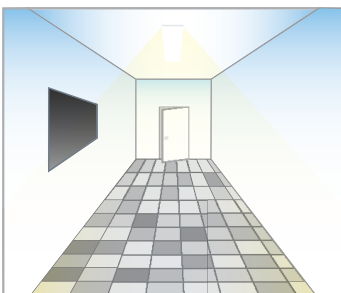
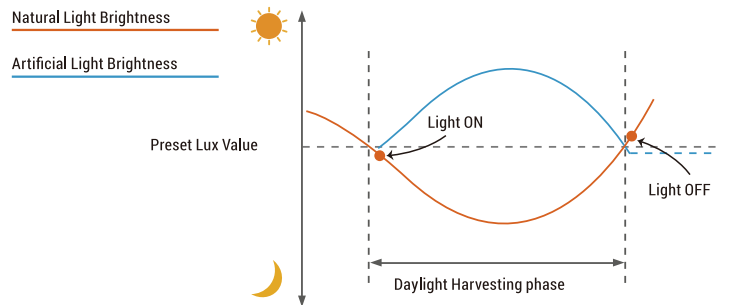

When ambient brightness is lower than preset lux level, sensor will turn on light automatically and keep dimming according to the change of the ambient brightness; when outside is getting darker, the inside will be brighter, and brighter darker.

Light OFF when ambient brightness becomes higher than the preset lux level.

Project Name:	Notes:	Date:	Type:
---------------	--------	-------	-------

2. DUSK/DAWN FUNCTION

PT-UNI2-SP-PR is able to differentiate artificial light brightness from natural light after installed inside the fixture, and automatically turn off light when ambient brightness exceeds preset lux level.

Precondition of Dusk/Dawn function:

1. Standby period is +∞;
2. Standby dimming level is on 10%, 20% or 30%;
3. Daylight threshold is on 30lux/50lux/80lux/120lux/200Lux/250Lux/300Lux/350Lux/400Lux

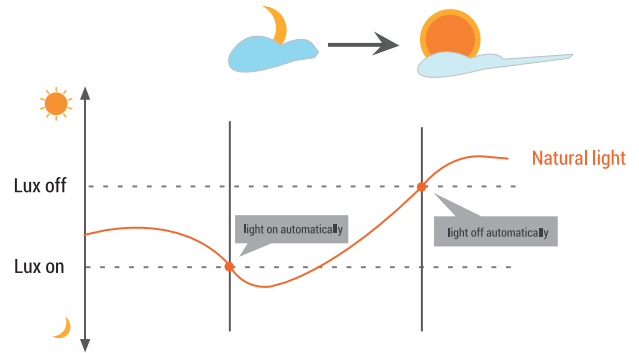

3. WITH DUSK/DAWN FUNCTION

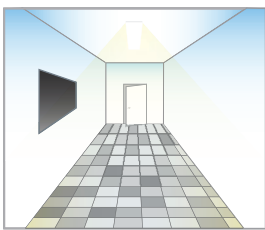

With insufficient ambient brightness, sensor turns on light and keeps it at standby dimming level even if there is no motion or presence.

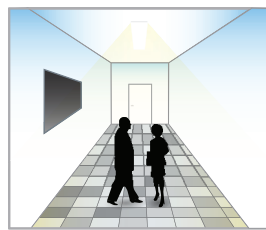

When sensor detects motion or presence it will bring the light level up to 100%.

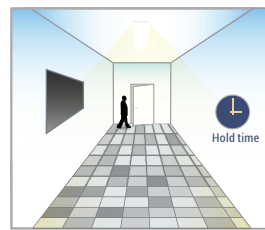

After motion is no longer detected, fixture remains at 100% for hold time.

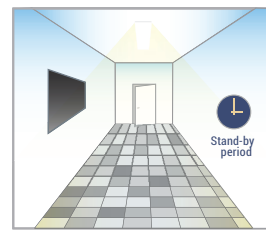

After preset hold time period it will dim light to standby dimming level again and always keep it.

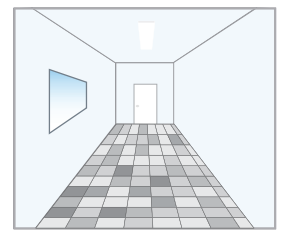

With sufficient ambient brightness, sensor will turn OFF light automatically.

4. WITHOUT DAYLIGHT DISABLED



Sensor turns ON light when motion is detected.

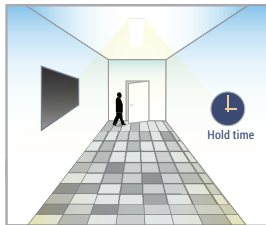

Sensor keeps for a hold time period after motion leaves.

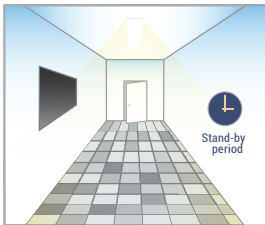

Sensor dims light to standby dimming level after hold time if there is still no motion.

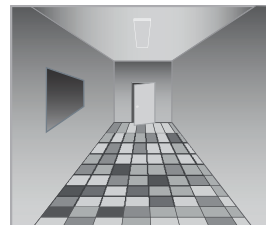

Sensor turns OFF light after standby period.

5. WITH DAYLIGHT THRESHOLD

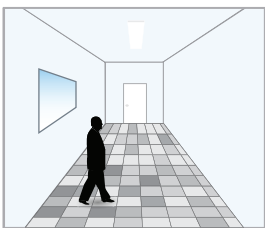

With sufficient daylight, the sensor keeps light OFF even motion gets detected.

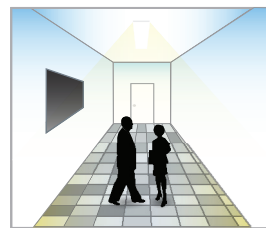

With insufficient daylight, the sensor turns light ON when motion gets detected.

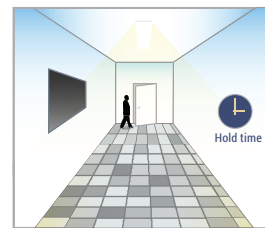

After there's no motion detected, the sensor keeps light ON 100% for holdtime.

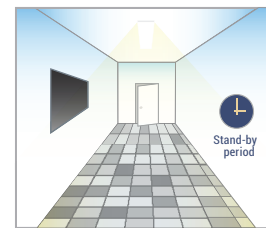

After holdtime, sensor dims light to standby dimming level for standby period. If the standby period has been set as 0s, sensor turns light OFF automatically after holdtime.

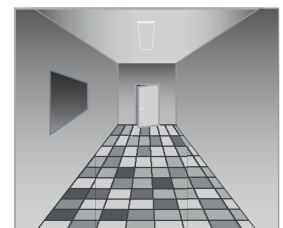

The sensor turns OFF light automatically after the standby period when there's no motion detected.